

Concealed Dual-Flush Technology Tank (UP320) System for Rear or Floor Outlet Toilets



Model 109.304.00.5

Product Specifications

Concealed tank with actuator flush panel or pneumatic push button for residential washdown floor mounted toilets with rear water inlet toilets. System shall fit within 51 1/2" (146 mm) framing wall or plumbing chase. Framing members should provide support similar to 2" x 6" (51 mm x 152 mm) wood construction or steel framing members placed 19 3/4" (500 mm) apart. Water supply shall have flow diameter no smaller than 1/2" (13 mm) copper tube, and a minimum flow pressure of 2 PSI (0.01 MPa). The toilet bowl shall be a third party listed low-consumption 1.6 GPF (6 LPF) or 1.6/0.8 GPF (6/3 LPF) dual-flush floor mounted toilet with rear water inlet type. Actuator flush panels shall be diecast zinc, molded plastic or fabricated stainless steel and plated to preserve material integrity. All components shall be compliant with applicable codes and product standards.

Warranty

Limited lifetime warranty on tank, 10-year warranty on fill valve and flush valve. One-year warranty on actuator flush panels.

Features

- Water consumption – Dual-flush system allows 1.6/0.8 GPF (6/3 LPF), giving effective flush volume of 1.1 GPF (4 LPF)
- Anti-siphon fill valve
- Impact resistant high density polyethylene (HDPE) tank, insulated to prevent condensation
- Bowl rim height depends on ceramic chosen. See manufacturer for details.
- For finished walls up to 3.5" (9cm) thick
- Medium inspection opening for flush actuator plates Sigma, Bolero, Samba, Mambo, Tango, Rumba
- Includes installation and rough-in materials

Complies with the latest editions of:

- ASME: A112.19.5, A112.19.14
- ANSI Z124.4
- CSA B125.3
- ANSI/ASSE 1002
- IAPMO PS-50
- UNAR / UNAR-HET
- ASME A112.19.2
- This concealed tank is WaterSense® compliant when used in combination with the toilet bowl models listed on page 2 of this sheet.

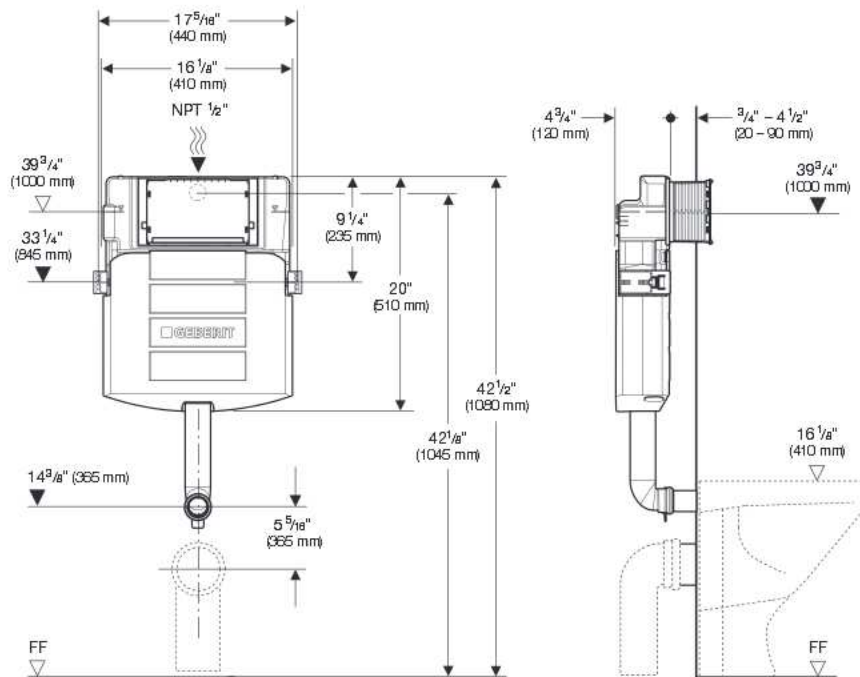

Product specifications subject to change without notice.

ARCHITECT/ENGINEER APPROVAL	
Job Name	_____
Date	_____
Quantity	_____
Model Specified	_____
Variations Specified	_____
Customer/Wholesaler	_____
Contractor	_____
Architect	_____

Geberit
2100 S. Clearwater Drive
Des Plaines, IL 60018

800/566-2100
Fax 847/803-5454
www.geberit.us

Concealed Dual-Flush Technology Tank (UP320) System for Rear or Floor Outlet Toilets



Model 109.304.00.5



Watersense EPA High Efficiency Compatible Wall-hung Toilet Bowl Models

Geberit Tank and Carrier Model No.	Bowl Brand Name	Bowl Model No.	Bowl Model Name
109.304	Duravit	211709	Vero

Other Compatible Wall-hung Toilet Bowl Models

Geberit Tank & Carrier Model No.	Bowl Brand Name	Bowl Model No.	Bowl Model Name
109.304	Duravit	220409	Starck X